

Inverse Square Law and Polarization

Objectives: To show that light intensity is inversely proportional to the square of the distance from a point light source and to show that the intensity of the light transmitted through two polarizers depends on the square of the cosine of the angle between the axes of the two polarizers.

Apparatus: 1 Pasco Optics Bench (OS-8518)
2 Point light sources (OS-8517)
1 Photometer with filter set (OS-8520)
2 Polarizers (OS-8520)

Explanation:

Inverse Square Law: The light from a point light source spreads out uniformly in all directions. The intensity at a given distance, r , from the light will be equal to the power output of the light divided by the surface area of the sphere through which the light has spread. Since the area of the sphere varies as the square of its radius, r , the intensity will drop off as $\frac{1}{r^2}$. In general, the intensity of the point light source at any distance, r , is given by

$$I = \frac{\text{constant}}{r^2} \quad (1)$$

Thus, the ratio of the intensity (I) of the light at a position (r) as compared to the reference intensity (I_0) measured at a position (r_0) is given by

$$\frac{I}{I_0} = \frac{r_0^2}{r^2} \quad (2)$$

Polarization: A polarizer only allows light which is vibrating in a particular plane to pass through it. This plane forms the “axis” of polarization. Unpolarized light vibrates in all planes. Thus if unpolarized light is incident upon an “ideal” polarizer, only half will be transmitted through the polarizer, and the transmitted light is polarized in one plane. (In reality, no polarizer is “ideal” and less than half the light is transmitted.) If this polarized light is incident upon a second polarizer, the axis of which is oriented perpendicular to the plane of polarization of the incident light, no light will be transmitted through the second polarizer as in the figure below.

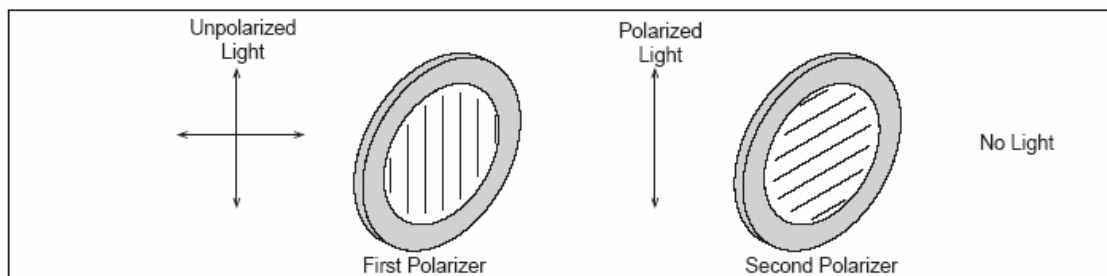

However, if the second polarizer is oriented at an angle that is not perpendicular to the first polarizer, there will be some component of the electric field of the polarized light that lies in the same direction as the axis of the second polarizer, and thus some light will be transmitted through the second polarizer as in the figure on the next page.

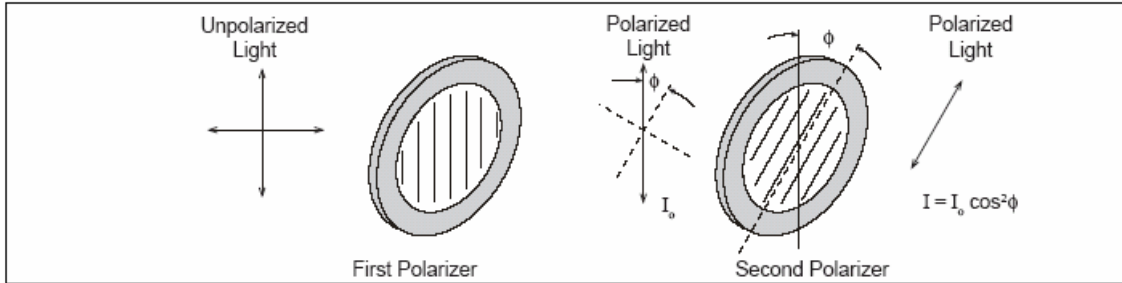

The component, E , of the polarized electric field, E_0 , is $E = E_0 \cos\phi$. Since the intensity of the light varies as the square of the electric field, the transmitted light intensity is given by

$$I = I_0 \cos^2 \phi \quad (3)$$

where I_0 is the incident light intensity and ϕ is the angle between the axis of polarization of the incident light and the polarizer.

How to Use the Photometer:

To determine if the two sides of the photometer are illuminated by light of equal intensity, look down into the conical eyepiece of the photometer. The cone is designed to cast a shadow on the inner parts of the photometer to allow a better view.

Do not put your eye directly on the eyepiece.

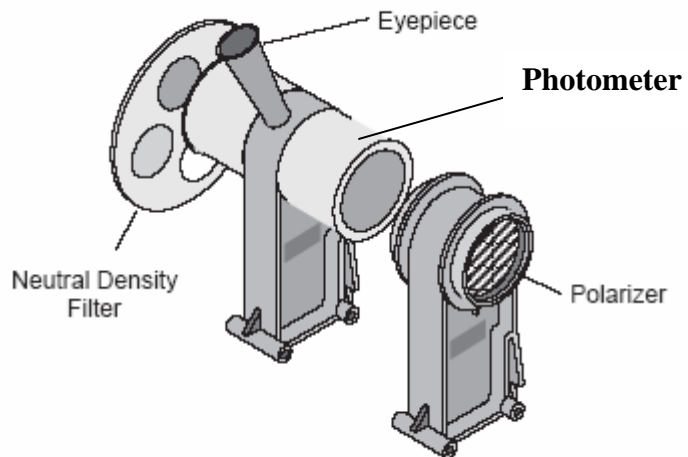

Keep your head at a distance which allows you to comfortably focus on the orange indicator.

By looking through the eyepiece, you can see if the disks, each receiving light from an opposite side of the photometer, are equal in intensity. Although it is difficult for the eye to determine relative intensities, it can detect equal intensities quite accurately

Setup for Part 1: Inverse Square Law

1. Place the photometer at the 70 cm mark on the optics bench.
2. Place a point light source at 40 cm. This is light source “1”. Put a neutral density filter on the side of the photometer that is opposite the point source. Place the other light source on the same side of the bench that has the neutral density filter. This is light source “2”.
3. Adjust the neutral density filter for 100% transmittance.

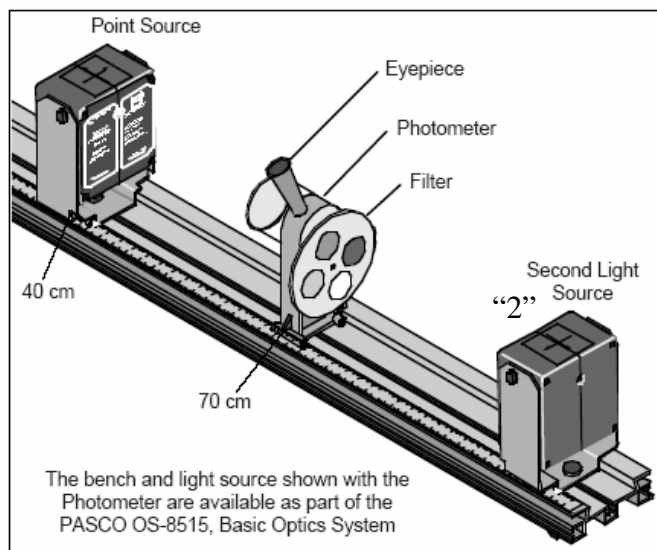

**WHEN MOUNTING AND UNMOUNTING THE LIGHT SOURCE,
DO NOT REMOVE THE SQUARE NUTS.**

Procedure Part 1: Inverse Square Law

NOTE: You may want to cover the crossed-arrow object on each light source to reduce the excess light in the room.

The lights in the room need to be off or very dim.

Remember to include uncertainty of your measurements and to propagate error.

1. Look into the photometer and move the light source “2” (on the filter side) to a position that gives equal intensities. The light source “2” will remain at this position for the rest of the experiment and will serve as the reference intensity I_0 . Record the positions of the photometer and the light source “1” (opposite the filter side of the photometer) in Table 1. The position of the reference light is not needed.
2. Rotate the neutral density filter to 75% transmittance. Move the point light source “1” to the position where the intensities are once again the same when viewed in the photometer. Record this new position of the light source in Table 1.
3. Repeat the last step for 50% and 25% transmittance.
4. Without moving the photometer, repeat the above steps for three more trials.

Analysis:

1. Using the measured positions in Table 1, calculate the distances of the point source from the photometer and record in Table 1.
2. For each of the different positions, calculate the intensity in terms of I_0 . Use r_0 as the initial distance of the point source (100%) and r as the distance at the given intensity. Note that the intensity is calculated in terms of the initial intensity I_0 . Record your answers in Table 1.
3. Calculate the percent difference between the calculated intensities and their corresponding expected values. Record in Table 1.

Questions:

1. Based on your results, how does the intensity of light vary with distance? (Explain in three or more sentences.)

Setup for Part 2: Polarization

1. Use the same general set up as in Part 1.
2. Snap one polarizer onto each side of the accessory holder. Before beginning the experiment, check the angle calibration on the polarizers in the following way: On the side of the accessory holder that has the label, set the angle to 90 degrees. Look through both polarizers at a bright light and rotate the other polarizer until the transmitted light is at the minimum. Now the polarizers are crossed at 90 degrees. Rotate the label side polarizer back to zero degrees.
3. Now the two polarizers are aligned for maximum transmission.
4. **Throughout the experiment, only rotate the label-side polarizer.**
5. Place the polarizer accessory holder (with polarizers) on the bench between the light source and the photometer on the side opposite the neutral density filter. The label side of the polarizer holder should face away from the photometer. The polarizer holder should be close to the photometer so only polarized light will enter that side of the photometer.

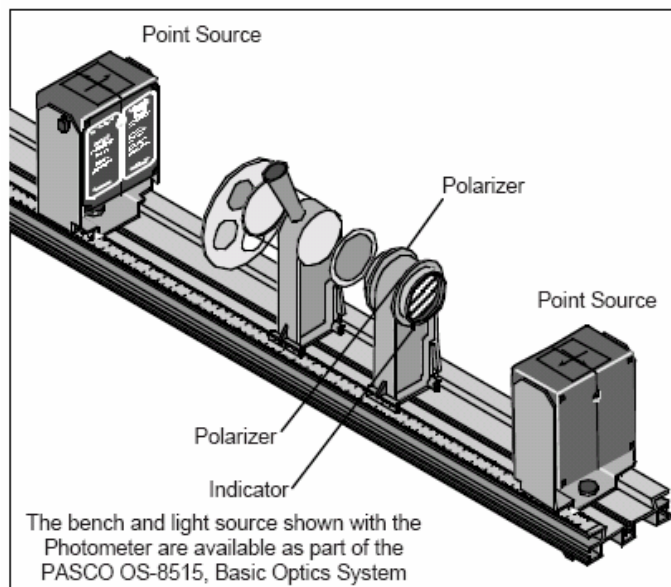

Procedure part 2: Polarization

NOTE: You may want to cover the crossed-arrow object on each light source to reduce the excess light in the room.

The lights in the room need to off or very dim.

Remember to include uncertainty of your measurements and to propagate error.

1. Set the neutral density filter for 100% transmission.
2. While looking into the photometer's conical eyepiece, adjust the position(s) of the light source(s) until the two sides of the orange indicator have equal intensity.
3. Set the neutral density filter for 75% transmission.
4. While looking into the photometer's conical eyepiece, rotate the label-side polarizer until the two sides once again have equal intensity. Record the angle in Table 2. Rotate the polarizer back to zero and repeat the measurement three more times.
5. Repeat the previous step for 50% and 25% transmission.

Analysis

1. For each of the neutral density filter settings, calculate the average of the three trials and record the average angle in Table 2.
2. To calculate the predicted percentage transmittance for each case, calculate the square of the cosine of each average angle and record in Table 2.
3. Calculate the percent difference between the percentage transmittance and the predicted value for each case and record in Table 2.

Questions:

1. Since an ideal polarizer does not exist, less than half the light is transmitted. How does this impact your results?
2. Did you verify Eq. (3)?
3. How could you determine the polarization axis of a pair of polarized sunglasses?

Name: _____

Date: _____

Partner: _____

Inverse Square Law and Polarization

Table 1: Inverse Square Law

| Photometer Position = _____ | | Light Source Intensity | | | |
|--|----------------|------------------------|-----|-----|-----|
| | | 100% | 75% | 50% | 25% |
| Position 1 | Trail 1 | | | | |
| | Trail 2 | | | | |
| | Trail 3 | | | | |
| | Trail 4 | | | | |
| Average Position of Point Source | | | | | |
| Distance from Photometer | | | | | |
| Calculated Intensity (% of I₀) | | X | | | |
| % difference | | X | | | |

Table 2: Polarization

| % Transmittance | 75% | 50% | 25% |
|--|------------|------------|------------|
| Trial 1 | | | |
| Trial 2 | | | |
| Trial 3 | | | |
| Average angle ϕ | | | |
| $\cos^2\phi$ | | | |
| % difference | | | |

Work Safely